

A Design Of Omni-Directional Mobile Robot Based On Mecanum Wheels

*Zhou Jun

School of Mechanical Engineering, Shanghai University of Engineering Sciences, Shanghai 201620, China

**Corresponding author: *Zhou Jun*

ABSTRACT:As one of the important branch of mobile robotics, wheel mobile robot has long been paid attention to by the research people at home and abroad for its high load ability, positioning accuracy, high efficiency, simple control, etc. Mobile robot has close relation to many technologies such as control theory, computer technology, sensor technology, etc. Therefore, research on the mobile robot has important significance.

keywords: Mobile robot; Four wheel drive and steering; Mecanum wheels

I. INTRODUCTION

The development of robot technology had produced large influences on human society. First, robots are used at the places where repetitive work is needed. Robots can not only accomplish human tasks but also they can fulfill the tasks more efficient and faster. Second, robots are used to represent humans to fulfill the tasks in dangerous and deleterious situations. Last, robots are used at the places where humans can not reach at present such as abyssal seas and narrow places. Autonomous land vehicle is roughly divided into several kinds which are WMR, leg mobile robot, crawler mobile robot and jump mobile robot. WMR has good performs which are strong carrying capacity, simple driving and controlling, moving easily, positioning precisely, high energy utilization and enough research productions now. So research specialist staff are prefer to WMR. This article adopts 45 degrees Mecanum wheels and the four wheels are driven independently so it can accomplish the movement of three free degrees in-plane. It can work competently in narrow and limited space as it is maneuverable.

1 Operational principle

Independent Mecanum wheels can not achieve omni-directional mobile. And there should be at least four Mecanum wheels to form omni-directional mobile platform. And it is necessary to conduct kinematic analysis on this omni-directional mobile platform to provide theory evidences for the control algorithm. Figure 1 is a kind of Mecanum wheel. Figure 2 is a kind of typical omni-directional mobile platform which adopts four Mecanum wheels.

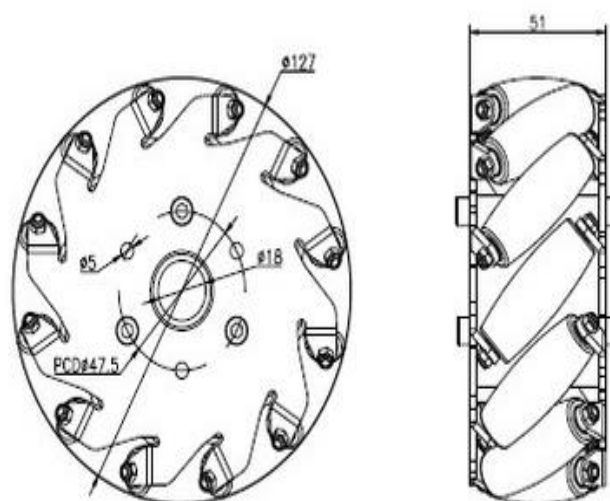

Figure 1 A kind of Mecanum wheel

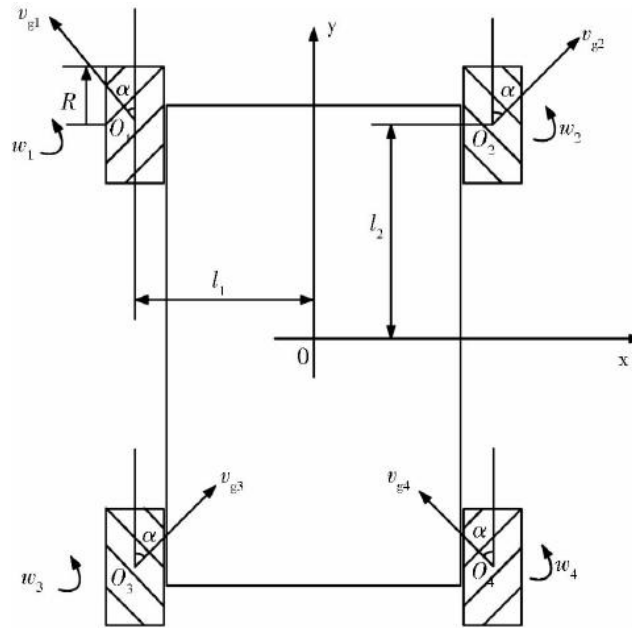

Figure 2 Typical wheels' arrangement for omni-directional mobile platform

As figure 1 shows, the rollers can realize two free degrees' movement. One is rotary motion which is around the central axis. Another is rotary motion which is around the rollers' axes. Establish global coordinate system O_{xy} according to the center point O of the mobile platform, O_{xy} is relatively static to ground; O_i is the center of wheel i . Omni-directional mobile platform has three free degrees on a flat surface, the velocity of its central point O is $[V_x, V_y, W_z]$, the angular velocity that wheels revolve around wheels' axis is W_i . The velocity of wheel's center is O_i and the velocity of roller is V_{gi} .

When motors drive vehicle wheels to revolve, one vehicle wheel has two movements. One is going forward along the direction that is perpendicular to drive axis. Another movement is that the roller which touches the ground revolves around its axis. Take wheel one for example. The velocity that wheel's center in overall coordination system is:

$$V_1 = \begin{bmatrix} V_{1x} \\ V_{1y} \end{bmatrix} = \begin{bmatrix} 0 & -\cos\theta \\ R & \sin\theta \end{bmatrix} \begin{bmatrix} w_1 \\ v_{g1} \end{bmatrix} \quad (1)$$

On the other hand, wheel is fixed on mobile platform. According to the overall velocity of mobile platform, we can get that:

$$V_1 = \begin{bmatrix} 1 & 0 & -l_2 \\ 0 & 1 & -l_1 \end{bmatrix} \begin{bmatrix} V_x \\ V_y \\ w_z \end{bmatrix} \quad (2)$$

According to equation(1) and (2), we can get that:

$$\begin{bmatrix} 0 & -\cos\theta \\ R & \sin\theta \end{bmatrix} \begin{bmatrix} w_1 \\ v_{g1} \end{bmatrix} = \begin{bmatrix} 1 & 0 & -l_2 \\ 0 & 1 & -l_1 \end{bmatrix} \begin{bmatrix} V_x \\ V_y \\ w_z \end{bmatrix} \quad (3)$$

As for other three wheels, we can get same equation set. According to the equation set we can get a relational expression below:

$$\begin{bmatrix} w_1 \\ w_2 \\ w_3 \\ w_4 \end{bmatrix} = \begin{bmatrix} \frac{1}{R \tan \alpha} & \frac{1}{R} & \frac{-(l_2 + l_1 \tan \alpha)}{R \tan \alpha} \\ -\frac{1}{R \tan \alpha} & \frac{1}{R} & \frac{(l_2 + l_1 \tan \alpha)}{R \tan \alpha} \\ \frac{1}{R \tan \alpha} & \frac{1}{R} & \frac{-(l_2 + l_1 \tan \alpha)}{R \tan \alpha} \\ -\frac{1}{R \tan \alpha} & \frac{1}{R} & \frac{(l_2 + l_1 \tan \alpha)}{R \tan \alpha} \end{bmatrix} \begin{bmatrix} V_x \\ V_y \\ w_z \end{bmatrix} \quad (4)$$

J is Jacobian matrix of the inverse kinematics equation system. According to robot kinematic principle. When the system's inverse kinematics Jacobian matrix's column rank is not full, there will be singularity in the system to make the freedom of motion reduce. As for the configuration of this system's wheels. All of the angles are both acute angle. So every element in J matrix is not zero and rank(J)=3 at all time. That means this system can move at all direction.

As for omni-directional mobile system based on four Mecanum wheels. The inverse kinematics equation J reflects the mapping relationship between four rotating angular velocity and system's center velocity. So the character of inverse kinematics equation J also reflects system's kinetic characteristic.

II. THE CONTROL OF WHEEL'S VELOCITY

2.1 Motor speed's control

According to equation(4), we can know that we have to control each wheel's speed to realize each direction's movement. The control of four wheels' velocity and current is as follows:

With the development of electronic device, there are many motion controllers in the market. They can not only control the torques of motors, but also motors' speed of revolution. Robots adopt motion controllers to control motors' speed of revolution. So we can get the motion controllers from robot's kinematics model. And there is no need to think about robot's dynamic model. Figure 3 is L298N driver module. ENA is ENABLE. IN1、IN2 are the input ends of motor speed's control signal. Table 1 is the corresponding relationship picture of input ends and motor running states.

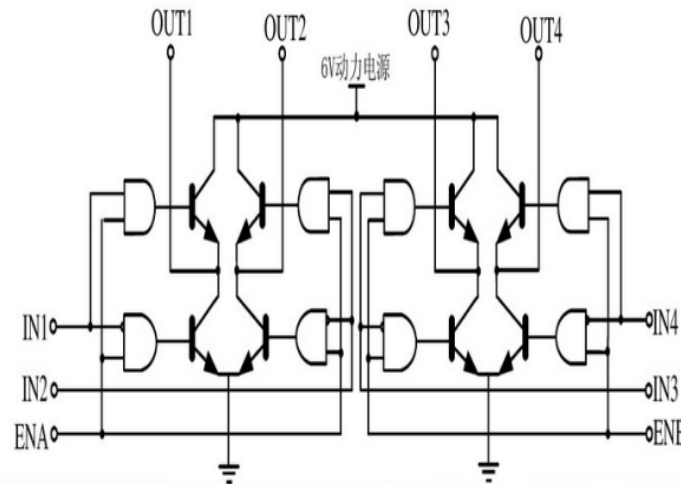

Figure 3 L298N driver module

IN1	IN2	ENA	Motor states
X	X	0	stop
1	0	1	clockwise
0	0	1	anticlockwise
0	0	0	stop
1	1	0	stop

Table 1 motor running states

DSP can use assembly language or C language to develop. Because of the rapidity of assembly language and the code is not very long. So I use assembly language to develop. Because the data size of SCI and CAN is big, so I use interrupt type of program design. And because it will enter the interrupt continually, polling type structure is adopted.

IV. CONTROL ALGORITHM

There are many kinds of control algorithm to control speed. Comparatively typical control algorithms are PI control and expert control which are applied in document[5]. Because this platform is based on the situation that needs high real-time. So I use expert PID control. Suppose that: $\square e(k) = e(k) - e(k-1)$

(5) **In equation:** $e(k)$ is the deviation between actual wheel's speed and ordered speed.

According to error and its change to design expert PID controller. It is divided into 5 situations as below:

(1) When $|e(k)| \geq M1$ and the absolute value of error is large. Controller should export maximal value.

(2) When $\Delta e(k) > 0$, if $|e(k)| \geq M2$, it means that error is comparatively large. Controller should exert comparatively strong control action. Its output

$$u(k) = u(k-1) + k1\{kp[e(k) - e(k-1)] + kIe(k) + kd[e(k) - 2e(k-1) + e(k-2)]\} \quad (6) \text{ If}$$

$|e(k)| < M2$, it means that though deviation is increasing but its absolute value is not large. Controller should exert normal control. The output is:

$$u(k) = u(k-1) + kp[e(k) - e(k-1)] + kIe(k) + kd[e(k) - 2e(k-1) + e(k-2)] \quad (7)$$

(3) When $\Delta e(k) < 0$ and $\Delta e(k-1) > 0$, the absolute value of deviation changes to the direction of diminishing. Controller tends to be stable and the output of controller should not change. (4) When

$\Delta e(k) < 0$ and $\Delta e(k-1) < 0$, the deviation is in limit value. If $|e(k)| \geq M2$, stronger control function should be exerted. $u(k) = u(k-1) + k1kpem(k)$ (8) If $|e(k)| < M2$, the

$$\text{output is: } u(k) = u(k-1) + k2kpem(k) \quad (9)$$

(5) When $|e(k)| \leq \varepsilon$ and the deviation is very small. It is needed to add integration to decrease steady-state error. In formula (15)-(17), $em(k)$ are deviation's k extreme values. $kp, k2$ and kd are PID's coefficients of proportion, integration and differentiation. $k1$ is gain factor, $k1 > 1$. $k2$ is the number of inhibition, $0 < k2 < 1$. $M1$ and $M2$ are set deviation threshold value; ε is lesser positive real number. The parameters above are given according to experts' experience.

V. CONCLUSION

Robot movement control system is the actuating mechanism of whole robot system. The robot car's performance has a great influence on whole system. This paper is based on logical hypothesis to analyze robot's motion model and introducing the achievement of robot's motion control. This kind of achieve method has some universality to omni-directional mobile robot. To satisfy the high demand of real-time performance. Calculation and theoretical hypothesis are simplified. As wheel-slip and ground grievances are not considered.

REFERENCE

- [1]. Jefri Efendi Mohd Salih, Mohamed Rizon, Sazali Yaacob, et al. Designing Omni-Directional Mobile Robot with Mecanum W-wheel[J]. American Journal of Applied Sciences, 2006,3 (5): 1831-1835.
- [2]. Samani, A.H., Abdollahi, A., Ostadi, et al. Design and Development of a Comprehensive Omni directional Soccer Player Robo-t[A], pp.191-200, International Journal of Advanced Robotic Systems, Volume 1, Number 3 (2004), ISSN 1729-8806.
- [3]. Fiegel, O., A. Badve and G. Bright, et al., Improved mecanum wheel design for omnidirectional robots[A]. Proc. Australasian Conf. Robotics and Automation, 2002, 27-29 Nov., pp: 117-121.
- [4]. Phillips, J.G., 2000. Mechatronic design and construction of an intelligent mobile robot for educational purposes. Master of Technology Thesis, Massey University, Palmerston North, New Zealand, pp: 15
- [5]. -J. Jung, H.-S. Kim, et al. Omnidirectional Mobile Base OK-II[A]. Proc. IEEE Int. Conf. Robotics and Automation. (2000) Vol. 4, pp. 3449-3454.

*Zhou Jun. "A Design Of Omni-Directional Mobile Robot Based On Mecanum Wheels." International Journal of Research in Engineering and Science (IJRES) 5.7 (2017): 62-66.